

Optimum Cost Design of Reinforced Concrete Columns Using Genetic Algorithms

Dr. Salim T. Yousif

Assistant Prof.

Civil Eng. Dept. - Mosul University

Rabi' M. Najem

Assistant Lecturer

Civil Eng. Dept. - Mosul University

Abstract

The aim of this study is finding the optimum cost design of reinforced concrete columns with all loading conditions (axially, uniaxially and biaxially loaded) using the Genetic Algorithms GAs. Many design constraints were used to cover all the reliable design results, such as limiting the cross sectional dimensions, limiting the reinforcement ratio and even the behavior of the optimally designed sections.

Each of the designed columns was handled by the GAs solver according to its loading condition specifications. The load contour method was used to design the biaxial sections with the adjustment of the plastic centroid. A long column constraint was introduced to limit the design procedure with the short columns only. The optimum results were compared with other published works, and a reduction in design cost of the biaxially loaded columns of about 26 % was achieved using the GAs design method while a small percent in the cost reduction (1 – 3 %) was achieved for the uniaxially designed sections, while 50% was the cost savings in the axially loaded columns. It was proved that the genetic algorithm is capable for designing optimum columns sections despite the complex constraints that control the designing procedure.

Key Words:- Optimization, Genetic Algorithm, Optimum Cost Design, Reinforced Concrete Columns

تصميم الكلفة الأمثل للأعمدة الخرسانية المسلحة باستخدام الخوارزميات الجينية

ربيع مؤيد نجم

مدرس مساعد

قسم الهندسة المدنية - جامعة الموصل

د. سالم طيب يوسف

أستاذ مساعد

قسم الهندسة المدنية - جامعة الموصل

الخلاصة

الهدف من هذه الدراسة هو إيجاد التصميم الأمثل للكلفة للأعمدة الخرسانية المسلحة تحت تأثير جميع حالات التحميل باستخدام الخوارزميات الجينية. تم استخدام العديد من محددات التصميم لتغطية أكبر عدد من الحلول المثلى لجعل التصميم قابلاً للتنفيذ، مثل تحديد أبعاد المقطع ونسبة حديد التسليح وحتى التحكم بطبيعة تصرف العمود بعد تصميمه تجاه الأحمال المسلطة عليه.

تم تحديد طريقة التصميم لكل عمود تبعاً للأحمال المسلطة عليه، واستخدام طريقة **load – contour** لتصميم الأعمدة المحملة بعزوم بالاتجاهين، مع تعديل المركز اللدن الخاص بالمقطع، واعتماد التصميم للأعمدة القصيرة فقط وفق محددات مسبقة.

و جرى مقارنة نتائج التصميم الأمثل مع نتائج منشورة مسبقاً. وتم الحصول على مقاطع أرخص بنسبة 26% في حالة الأعمدة المحملة بعزم ثنائي المحور وبنسبة أقل (1 – 3 %) في حالة الأعمدة المحملة بعزم باتجاه واحد، بينما قلت الكلفة بنسبة 50% في حالة الأعمدة المحملة مركزياً. وأثبتت طريقة الخوارزميات الجينية بقدرتها على التعامل مع مسائل على جانب من التعقيد كتصميم الأعمدة الخرسانية بوجود العديد من محددات التصميم.

. Received: 8 – 10 - 2012

Accepted: 9 – 6 - 2013

List of Symbols

ρ	: Steel reinforcement ratio for the designed section
f_c^-	: Concrete compressive strength
f_y	: Steel yield stress
P_u	: Applied load
ρ_{ten}	: Reinforcement ratio of the tension face
ρ_{com}	: Reinforcement ratio of the compression face
$\alpha 1, \alpha 2$: Exponents depending on the cross section geometry, steel percentage, and its location and material stresses f_c^- and f_y
$\rho_{ten,x}$ and $\rho_{com,x}$: Reinforcement ratio of the tension face and the compression face in the x direction
$\rho_{ten,y}$ and $\rho_{com,y}$: Reinforcement ratio of the tension face and the compression face in the y direction
A	: Cross sectional area
b	: Column width
C_c	: Cost of concrete material
C_s	: Cost of steel material
C_t	: Total cost of the section
h	: Column height
I	: Moment of inertia of the cross section
M_{nx}	: Applied moment in the x - direction, $P_n \times e_y$
M_{ny}	: Applied moment in the y - direction, $P_n \times e_x$
M_{ox}	: M_{nx} at such an axial load P_n where M_{ny} or $e_x = 0$
M_{oy}	: M_{ny} at such an axial load P_n where M_{nx} or $e_y = 0$
r	: Ratio of steel cost to concrete cost (C_s / C_c)
r_d	: Radius of gyration

1. Introduction

Genetic algorithms GAs, are iterative search procedures based on the mechanics of natural genetics and natural selections. GAs are computationally simple, but powerful in their search for improvement and do not require problem specific knowledge in order to carry out a search.

The simple genetic algorithms, which are applications of biological principles into computational algorithms, have been adapted to work with many kinds of structural design problems. It was used to obtain optimal or near-optimal solutions for many types of discrete or continuous variables in structural design problems and it dose not need derivatives of functions unlike mathematical programming methods.

For structures made of two or more different materials, minimum weight has no meaning with respect to optimization. Optimization has to be formulated as minimum cost. Hundreds of papers have been published on optimization of structures. However, only a small fraction of them deal with cost optimization of structures. For concrete structures the

objective function to be minimized should be the cost since they are made of more than one material [1].

The basic element of the GAs is the chromosome. The chromosome contains the variable information for each individual solution to the problem. The most common coding method is to represent each variable with a binary string of digits with a specific length. For example, as illustrated in Fig.(1), to represents the column in GAs, each of the design variables shown in the figure, should be encoded into a binary digits to assemble the genes that forming each chromosome. The chromosome contains six genes. To represents column width, column height and the reinforcement ratio which will be represents by four genes, each gene stands for the reinforcement ratio of a single face of the column section, this procedure was adopted to ensure that the optimization design will fulfill its purpose, which it will not be happened if the reinforcement ratio is taken to be equal for all the faces of the section [2].

After that, Random numbers are used to generate the 1's and 0's that represent the genetic material of each individual. The genetic algorithm sequence begins with the creation of an initial population of individuals. The size of the population is chosen by the program user. With the chromosomes created, the binary string data of each solution must be converted into useable problem data. Evaluation of the fitness value is then started, which in this study will be the cost of the structure, and a roulette selection is adopted to the chromosomes for creating the next generation. The crossover process now begin, which is the process by which the genetic material of two "parents" will be combined to create a new solution. Different selection methods exist for choosing the parents to be involved in each crossover. The method used in this project is referred to as scattered crossover. A group of the most-fit parents, along with the newly created individuals, are allowed to pass into the new generation with an account of 2. The less-fit solutions are discarded. At this time, the genetic material of the individuals is subject to mutation operation. A small percentage of individuals in the population have one or more of their binary digits altered. Mutation forces the genetic algorithm to explore new areas of the search space.

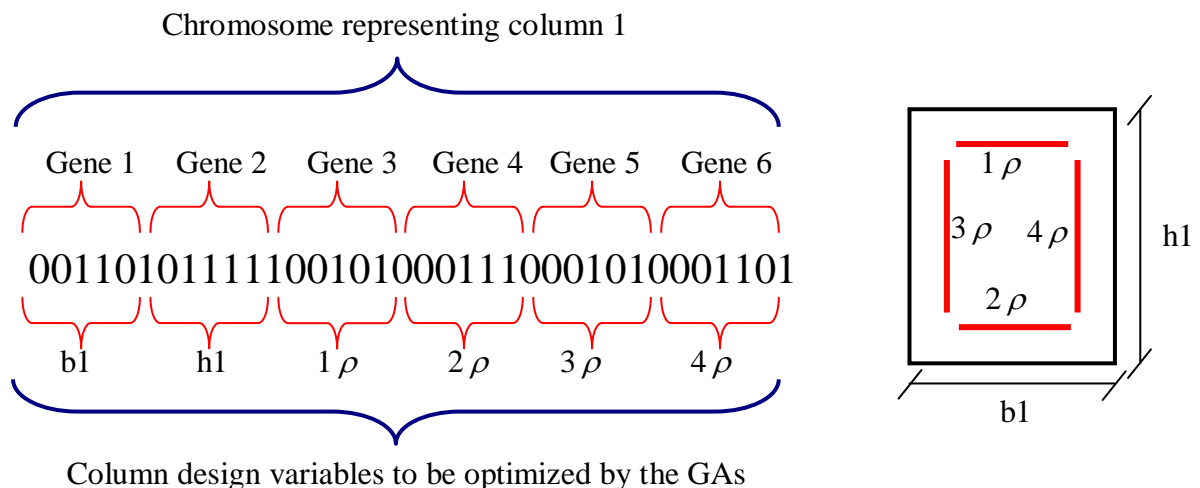

Fig. (1) Genetic Algorithm representation for column

Elitism is used at this time also. Elitism protects a certain number of the most-fit individuals from mutation. Although exploring new areas of the search space is beneficial, keeping the genetic material of highly-fit individuals is sometimes preferred. So, as a result, a

new generation will be found that represents the optimum solution of the design variables submitted to the design constraints that control their values through the GAs solution with the used code limitations and the bounds of the design variables [3].

Finally, after all the GAs operations are performed and the entire process is repeated. The amounts of generations will cycle through per “evolution”. The GAs can run until one of the stopping criteria is reached. The most stopping criteria were reaching the function tolerance.

Fadaee and Grierson [4], present the minimum cost design of three dimensional RC frames with members subjected to biaxial moments and shear forces using optimality criteria approach based on the ACI code (ACI, 1995). Beams and columns are assumed to have rectangular sections. The cost function includes the material costs of concrete, steel, and the formwork. The focus of this work is formulation of the appropriate constraints for combinations of the axial load, biaxial bending moment, and biaxial shear. Their example is only a one-bay and one-story space frame. They conclude that the biaxial shear is an important consideration for the design of columns and its inclusion increases the cost of the optimum structure significantly.

The reinforcing steel bar number and the number of the bars or topology of the reinforcement were used by *Camp, et. al.* [5], as design variables with the width and the thickness of the sections, for the design of reinforced concrete frames using the genetic algorithm and a penalized objective function was used for forming an unconstrained problem in order to introduce feasibility into the fitness of the solution, with flexural constraints for beams and slenderness effect for columns.

Kwak and Kim [6], adapted an algorithm to evaluate the fitness values of many sections by constructing a database that contain 2450 sections for beams and the same for columns, these section were submitted to some practical limitations such as: the column dimensions shall not be less than 30 x 30 cm with a depth to width ratio about 1 – 2, and for beam 20 x 35 cm with a depth to width ratio about 1.5 – 2.5, also these dimensions were rounded to the nearest 5 cm. As for the reinforcement, the sections were reinforced with a ratio between the minimum and the maximum in order to insure handling the applied loads. For columns design, the P – M interaction diagram was divided into three zones depending on the boundary values of the eccentricity. For beam design, the sections were designed to resist two applied moments, the first is at the face of the support and the other is at the mid-span. These sections were used to design a multi bay – multi story plane frames.

Aschheim, et al. [7], obtained a general solution for the optimal reinforcement of rectangular reinforced concrete sections for a general P, M_x & M_y load combination to represent beams, columns & wall sections using a nonlinear conjugate gradient search technique, taking the reinforcement ratio as a design variable only and leaving the section dimensions to be assumed according to the ACI Code (2005) limitations.. Some considerations was taken into account to match the provided reinforcement with the optimal solution. The optimal solution was found in many ways such as: equal reinforcement on all faces, equal reinforcement on opposite faces and unique reinforcement on each face.

The Genetic Algorithm was used by *Sahab* [8], to find the optimum cost of flat slab buildings including the cost of material and labor for concrete, reinforcement, formwork of floors, columns and foundations. Also investigating the influence of the unit cost of the materials and their characteristic strength on the optimum design. The design variables were represented by the slab thickness and dimensions, the reinforcing steel and its distribution, columns dimensions (which was assumed to be equal) with its reinforcing steel.

The effect of the unit cost was studied through a numerical example which was chosen from a report on the comparative costs of concrete and steel framed office building that has been recommended to be a benchmark for future studies.

In this paper, the optimum cost will be found for axially, uniaxially and biaxially loaded reinforced concrete columns using GAs. Also, the effect of materials prices for both steel and concrete on the optimum design will be conducted.

2. Optimum Design for Axially Loaded Columns

2.1 Objective Function

The cost function is represented by eq. (1), which will be the cost of concrete and steel materials.

$$C_t = C_c \times b \times h \times \{ 1 + (r \times \rho) \} \quad \dots\dots\dots(1)$$

where: r represent the ratio of 1 m^3 steel cost to a 1 m^3 concrete cost, which was equal to 75 in this study. Since the weight of 1 m^3 of steel is equal to 7850 kg, with price of 750000 ID, and the price of 1 m^3 of concrete is equal to 75000 ID, so the cost ratio of 1 m^3 of reinforced concrete will be ($r = 7850 \times 750000 / 75000$) which is about 78.5 .

While the design variables will be the dimensions of the column and the reinforcement ratio, considering that the width and the height of the column section will be equal.

2.2 Design Constraints

To achieve the optimum solution using the GAs, design constraints for the problem should be defined. For the axially loaded column, the used design constraints were: the maximum design strength of the section, eq. (2).

$$\frac{P_u}{0.65 \times 0.8 \times [(0.85 \times f_c^- \times ((b \times h) - (\rho \times b \times h))) + (f_y \times (\rho \times b \times h))]} - 1 \leq 0 \quad \dots\dots\dots(2)$$

In order to limiting the reinforcement ratio with maximum and minimum values, using eqs. (3) and (4), according to the ACI code (10.9.1)[9].

$$\frac{\rho}{0.08} - 1 \leq 0 \quad \dots\dots\dots(3)$$

$$1 - \frac{\rho}{0.01} \leq 0 \quad \dots\dots\dots(4)$$

For ensuring that the optimum dimensions of the column will not be less than a specified limit, using eqs. (5) and (6).

$$1 - \frac{b}{0.3} \leq 0 \quad \dots\dots\dots(5)$$

$$1 - \frac{h}{0.3} \leq 0 \quad \dots\dots\dots(6)$$

And finally a constraint to make the optimum section symmetrical as specified previously to achieve the axially loaded column requirements, eq. (7).

$$b - h = 0 \quad \dots\dots\dots(7)$$

3. Optimum Design for Eccentrically Loaded Columns

3.1 Objective function

The cost function of this kind of loaded column will not be differs from the case of the axially loaded column except that in this case the reinforcement ratio will be divided into two parts, one for the tension face and the other is for the opposite compression face. Since the optimization demands requires that the reinforcement ratio is not necessary equals at the faces of the column, other wise it is not an optimization problem except for the case of axially loaded column as explained before. The cost function represents by eq. (8) that contains the following design variables:

$$C_t = C_c \times b \times h \times \{ 1 + (r \times (\rho_{ten} + \rho_{com})) \} \quad \dots\dots\dots(8)$$

3.2 Design constraints

Since there are so many equations that control the strength of the column cross section and affects its optimum design, compromising the design variables to find the optimum solution will be a little bit harder than any other case so far.

The constraints function will be written in term of the design variables, and since it should be decided before the solution is started whether the designed constraints will be following a compression design condition or a tension design one. Therefore, in this study, the design constraints will be towards the balanced condition, after that, the suboptimal dimension will be chosen to make the column under compression.

The first three constraints, were for limiting the applied force with the balanced force of the section, also the applied moment will be limited to the balanced moment of the section meaning that (e is equal to $e_{balanced}$).

$$P_n - P_{bal} = 0 \quad \dots\dots\dots(9)$$

$$\left(\frac{M_n}{M_{bal}} - 1 \right) \leq 0 \quad \dots\dots\dots(10)$$

$$\left(\frac{e}{e_{bal}} - 1 \right) \leq 0 \quad \dots\dots\dots(11)$$

$$P_{bal} = 0.85 \times f_c^- \times a \times b + f_{s,com}^- \times \rho_{com} \times b \times h - f_{s,ten} \times \rho_{ten} \times b \times h \quad \dots\dots\dots(12)$$

$$M_{bal} = 0.85 \times f_c^- \times a \times b \times \left(y^- - \frac{a}{2} \right) + f_{s,com}^- \times \rho_{com} \times b \times h \times (y^- - d^-) \quad \dots\dots\dots(13)$$

$$+ f_{s,ten} \times \rho_{ten} \times b \times h \times ((h - d^-) - y^-)$$

$$a = \beta 1 \times c_{bal} = \beta 1 \times \left(\frac{0.003 \times E_s}{(0.003 \times E_s) + f_y} \times (h - d^-) \right) \quad \dots\dots\dots(14)$$

$$y^- = \frac{0.85 \times f_c^- \times b \times (h^2 / 2) + \rho_{com} \times b \times h \times f_{s,com}^- \times d^- + \rho_{ten} \times b \times h \times f_{s,ten} \times (h - d^-)}{0.85 \times f_c^- \times b \times h + \rho_{com} \times b \times h \times f_{s,com}^- + \rho_{ten} \times b \times h \times f_{s,ten}} \quad \dots\dots\dots(15)$$

$$e_{bal} = M_{bal} / P_{bal} \quad \dots\dots\dots(16)$$

$$e = M_n / P_n \quad \dots\dots\dots(17)$$

$$f_{s,com} = f_y - 0.85 \times f_c^- \quad \dots\dots\dots(18)$$

Where:

$$f_{s,ten}^- = f_y$$

$$\beta_1 = 0.85$$

$$E_s = 200000 \text{ MPa}$$

P_n : Applied force

M_n : Applied moment

The design constraints used for limiting the cross section dimension before in the axially loaded column, were also used for this case, by making the least dimension of a section is not less than (300 mm), and the ratio of the height of the cross section to the width is ranged from (1 to 2), with a minimum width of (500 mm). As can be seen from the following equations.

$$1 - \frac{b}{0.3} \leq 0 \quad \dots\dots\dots(19)$$

$$1 - \frac{h}{0.3} \leq 0 \quad \dots\dots\dots(20)$$

$$\frac{b}{0.5} - 1 \leq 0 \quad \dots\dots\dots(21)$$

$$\frac{h}{1.0} - 1 \leq 0 \quad \dots\dots\dots(22)$$

$$\frac{(h/b)}{2.0} - 1 \leq 0 \quad \dots\dots\dots(23)$$

$$1 - \frac{(h/b)}{1.0} \leq 0 \quad \dots\dots\dots(24)$$

The reinforcement ratio was also limited within the design code requirements, but in this case both ratios of the compression and tension steel were compared together with the minimum and maximum ratio of reinforcement, eqs. (25) and (26).

$$\left(\frac{(\rho_{ten} + \rho_{com})}{0.08} \right) - 1 \leq 0 \quad \dots\dots\dots(25)$$

$$1 - \left(\frac{(\rho_{ten} + \rho_{com})}{0.01} \right) \leq 0 \quad \dots\dots\dots(26)$$

The new design constraint that was introduced for this problem was for limiting the ratio of the length of the column to its cross sectional dimensions, in order to ensure that the optimum design will follow the short columns design procedure. Otherwise, a whole new design constraints and a different procedure shall be adopted to find the optimum design of the slender columns. So, according to the ACI code (10.10.1)[9], the slenderness effect shall be neglected for the following case:

$$\frac{k_b \times l_u}{r_d} \leq 22 \quad \dots\dots\dots(27)$$

This equation is for the compression members that are not braced against sidesway.. The unsupported length of a compression member, l_u , shall be taken as the clear distance between floor slabs, beams, or other members capable of providing lateral support in the direction being considered. k_b , is the unsupported length factor, and its value depends on the support condition. But for this study, this factor is taken to be equal to (0.6), which represents the case between (fixed – fixed) and (fixed – hinge) supporting conditions. While, r_d represents the radius of gyration of the cross section, and is equal to:

$$r_d = \sqrt{\frac{I}{A}} \quad \dots\dots\dots(28)$$

Therefore, the last design constraints will be as follow:

$$\left[\left\{ \frac{(k_b \times l_u) / (\sqrt{(b \times h^3 / 12) / (b \times h)})}{22} \right\} - 1 \right] \leq 0 \quad \dots\dots\dots(29)$$

4. Optimum Design for Biaxially Loaded Columns

4.1 Load contour method

This method involves cutting a three dimensional failure surfaces at a constant value P_n , to give an interaction plane relating M_{nx} and M_{ny} . In other words, the contour surface can be viewed as a curvilinear surface that includes a family of curves, termed the load contours, [10].

The general non dimensional equation for the load contour at a constant load P_n may be expressed as follows:

$$\left(\frac{M_{nx}}{M_{ox}} \right)^{\alpha_1} + \left(\frac{M_{ny}}{M_{oy}} \right)^{\alpha_2} = 1.0 \quad \dots\dots\dots(30)$$

The moments M_{ox} and M_{oy} are the required equivalent resisting moment strengths about the X and Y axis, respectively.

Eq. (30) can be simplified using a common exponent and introducing a factor β for one particular axial value P_n such that the (M_{nx}/M_{ny}) ratio would have the same value as the (M_{ox}/M_{oy}) as detailed by Parme and associates. Such simplifications lead to:

$$\left(\frac{M_{nx}}{M_{ox}} \right)^{\alpha} + \left(\frac{M_{ny}}{M_{oy}} \right)^{\alpha} = 1.0 \quad \dots\dots\dots(31)$$

Where α would have a value of $(\log 0.5 / \log \beta)$. Fig. (2) gives a contour plot ABC from eq. (31), minimum value of β is (0.5) and the maximum value of β is (1), [11].

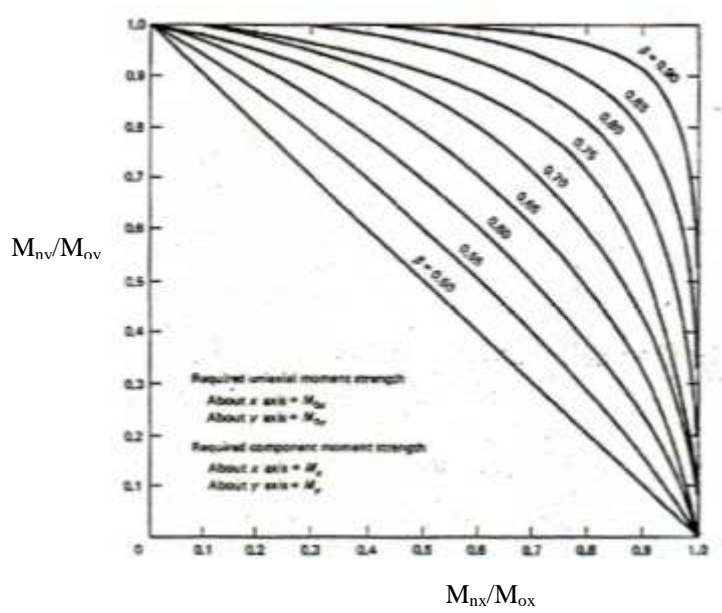

Fig. (2) Contour β factor chart for rectangular columns in biaxial bending

For design purposes, the contour is approximated by two straight lines BA and BC, Fig. (3), and eq. (31) can be simplified to two conditions:

- For AB when $(M_{ny} / M_{oy}) < (M_{nx} / M_{ox})$

$$\frac{M_{nx}}{M_{ox}} + \left(\frac{M_{ny}}{M_{oy}}\right) \left(\frac{1-\beta}{\beta}\right) = 1.0 \quad \dots\dots\dots(32)$$

- For BC when $(M_{ny} / M_{oy}) > (M_{nx} / M_{ox})$

$$\frac{M_{ny}}{M_{oy}} + \left(\frac{M_{nx}}{M_{ox}}\right) \left(\frac{1-\beta}{\beta}\right) = 1.0 \quad \dots\dots\dots(33)$$

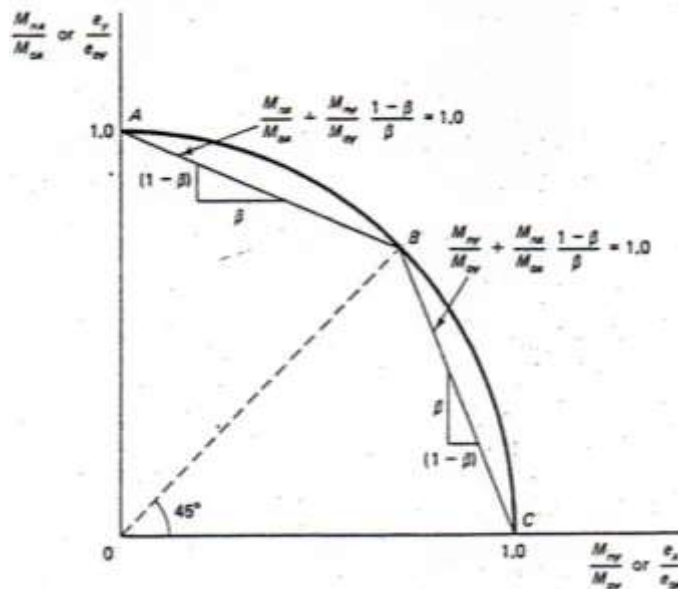

Fig. (3) Modified interaction contour plot of constant P_n for biaxially loaded columns

4.2 Objective function

The cost function of this case is the same as the previous one except that the steel reinforcement ratio will be divided in two parts for each direction, one for the tension face and the other is for the compression face at the same axis.

$$C_t = C_c \times b \times h \times \{ 1 + (r \times (\rho_{ten,x} + \rho_{com,x} + \rho_{ten,y} + \rho_{com,y})) \} \quad \dots\dots\dots(34)$$

The conflict of the reinforcement ratios for each other in the two directions will be disregarded, since there is no possible way to decide how many steel bars will be put in each face when the solution is started. Meaning that, each optimum reinforcement ratio will be found separately without any interaction of other ratios.

4.3 Design constraints

Since the basic idea of the load contour method is transforming the biaxial problem into an equivalent uniaxial one through eq. (31). This equation will be introduced as a new design constraint, and the problem will be solved uniaxially with M_{nx} considering ($e_x = 0$) and uniaxially with M_{ny} considering ($e_y = 0$), and then the new constraint will transform the effect of the solved procedure into a biaxial bending problem for both M_{nx} and M_{ny} .

$$\left(\frac{M_{nx}}{M_{ox,bal}} \right)^\alpha + \left(\frac{M_{ny}}{M_{oy,bal}} \right)^\alpha - 1.0 \leq 0 \quad \dots\dots\dots(35)$$

$$M_{ox,bal} = 0.85 \times f_c^- \times a \times b \times \left(x^- - \frac{a}{2} \right) + f_{s,com}^- \times \rho_{com} \times b \times h \times (x^- - d^-) + f_{s,ten} \times \rho_{ten} \times b \times h \times ((h - d^-) - x^-) \quad \dots\dots\dots(36)$$

$$M_{oy,bal} = 0.85 \times f_c^- \times a \times h \times \left(y^- - \frac{a}{2} \right) + f_{s,com}^- \times \rho_{com} \times b \times h \times (y^- - d^-) + f_{s,ten} \times \rho_{ten} \times b \times h \times ((b - d^-) - y^-) \quad \dots\dots\dots(37)$$

Also the plastic centroid in these equations will be found in two directions (X and Y) without any interaction of the bars positioning as explained previously. As for the slender column constraint, the two directions were taken into consideration, by replacing the height with the width in the other direction.

$$\left[\left\{ \frac{(k_b \times l_u) / (\sqrt{(b \times h^3 / 12) / (b \times h)})}{22} \right\} - 1 \right] \leq 0 \quad \dots\dots\dots(38)$$

$$\left[\left\{ \frac{(k_b \times l_u) / (\sqrt{(h \times b^3 / 12) / (b \times h)})}{22} \right\} - 1 \right] \leq 0 \quad \dots\dots\dots(39)$$

The reinforcement ratio constraint will have four parameters (two reinforcement ratios for each direction – for tension and compression face) as seen in Eqs. (40) and (41).

$$\left(\frac{(\rho_{ten,x} + \rho_{com,x} + \rho_{ten,y} + \rho_{com,y})}{0.08} \right) - 1 \leq 0 \quad \dots\dots\dots(40)$$

$$1 - \left(\frac{(\rho_{ten,x} + \rho_{com,x} + \rho_{ten,y} + \rho_{com,y})}{0.01} \right) \leq 0 \quad \dots\dots\dots(41)$$

And for the cross section dimensions, minimum and maximum dimensions are specified as seen in the following four equations for both width and height, without limiting them by any ratio between them.

$$1 - \frac{b}{0.3} \leq 0 \quad \dots\dots\dots(42)$$

$$1 - \frac{h}{0.3} \leq 0 \quad \dots\dots\dots(43)$$

$$\frac{b}{1.0} - 1 \leq 0 \quad \dots\dots\dots(44)$$

$$\frac{h}{1.0} - 1 \leq 0 \quad \dots\dots\dots(45)$$

After finding the optimum design variables, the same steps in finding the suboptimal solution that were used for the beam section are used. For the case of the suboptimal column section, one problem will be revealed here, which is the overlapping between the reinforcement ratios of each intersected faces, meaning that the bar sizes of the corners of the column section will have two values, each value came from one of the adjacent faces. In this case the maximum bar number is adopted to represents the suboptimal solution to ensure representing the optimum solution at one direction and as closest as it can to the optimum in the next direction.

5. Numerical Examples

5.1 Axially Loaded Columns Design

A 4 m height column was loaded axially with an applied force of $P_u = 4.06$ MN, having the following material properties $f_c = 30$ MPa and $f_y = 400$ MPa. The design constraints were as explained in the previous chapter, the width of the column cross section was limited to be equal to its height to ensure that the load is axially loaded. Also the long column constraint was not used in this example for comparison purposes.

Fig. (4), shows the optimum variables representing the cross section dimensions and the reinforcement ratio. Noticing on it, the limitations of the reinforcement ratio are with the minimum value

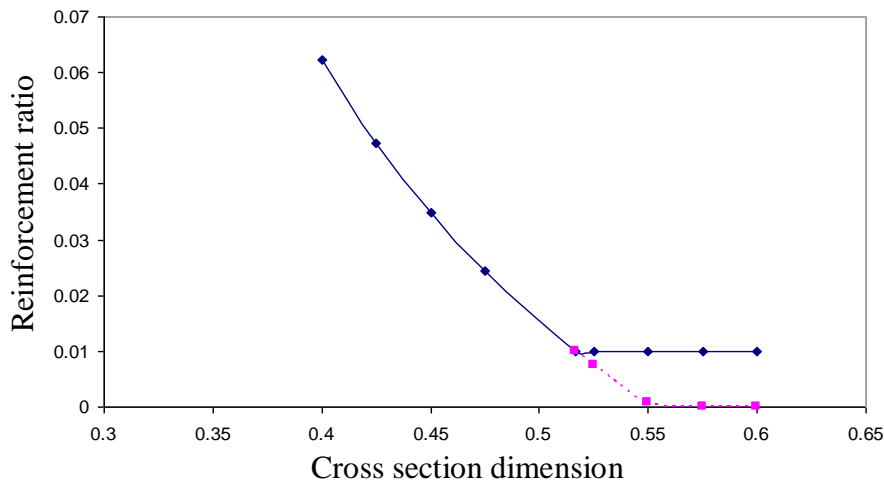

Fig. (4) Optimum solution for reinforcement ratio and section dimensions of axially loaded column

**Table (1) Cost design for optimum solution for an axially loaded column,
 $P_u = 4.06$ MN, $r = 75$, $f_y = 400$ MPa , $f_c = 30$ MPa**

Solution procedure	Reinforcement Ratio (ρ)	Cross section Dimension (mm)	Material Cost $\times C_c$ (\$ / m)
ACI (1)	0.0622	400	0.9064
ACI (2)	0.0473	425	0.8214
ACI (3)	0.03486	450	0.7319
ACI (4)	0.02431	475	0.637
GAs	0.011	516.7	0.4672
ACI (5)	0.01	525	0.4823
ACI (6)	0.01	550	0.5294
ACI (7)	0.01	575	0.5786
ACI (8)	0.01	600	0.63

The optimum cost was achieved through 12 iterations, also attainment nearly zero constraints violation. Table (1) shows the optimum designed section compared to other sections designed according to the ACI code with limited reinforcement ratio between 0.01 and 0.08. As its noticed in this table, many fixed section dimensions were taken to be designed and the reinforcement ratios were calculated according to this. It seems that the optimum cost section has a cost savings that reaches up to 50% to some designed sections.

5.2 Eccentrically Loaded Column Design

Different examples were designed optimally using Gas. The same examples were designed by *Nawy E. G.* [10] and *McCormac J. C.* [12]. These examples were solved without introducing the long column constraints for comparison, and then by using this constraint in addition to other constraints in designing these columns, some of the sections were affected by it, depending on the magnitude of the applied load and moments and the material properties of the columns.

5.2.1 Eccentrically Loaded column example - 1

The first example was solved by *McCormac J. C.* [12], the column was under factored load of $P_n = 3813.5$ kN and moment of 296.6 kN.m, $f_c = 27.6$ MPa and $f_y = 414$ MPa. The design results of this example are shown in Fig. (5), with a cost value of $0.552257C_c$. After solving the same example using the GAs, the optimum results are shown in Fig.(6) with a cost of $0.5435C_c$, the optimum solution was achieved through 8 iterations with zero constraints violation.

After rounding the optimum results, the suboptimum solution can be shown in Fig.(7). The same example was solved optimally again but this time with the long column constraint. The design results did not changed or affected by this factor.

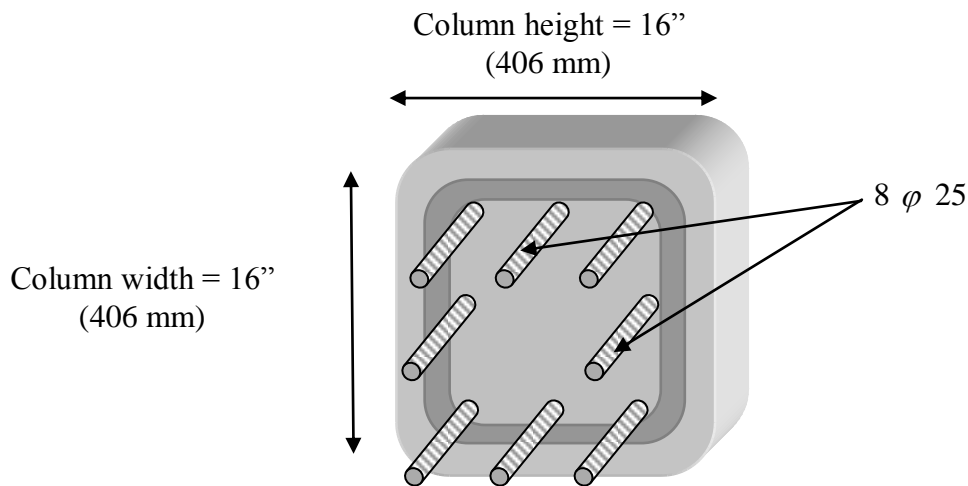

Fig. (5) Design of uniaxially loaded column, *McCormac J. C. 2001*

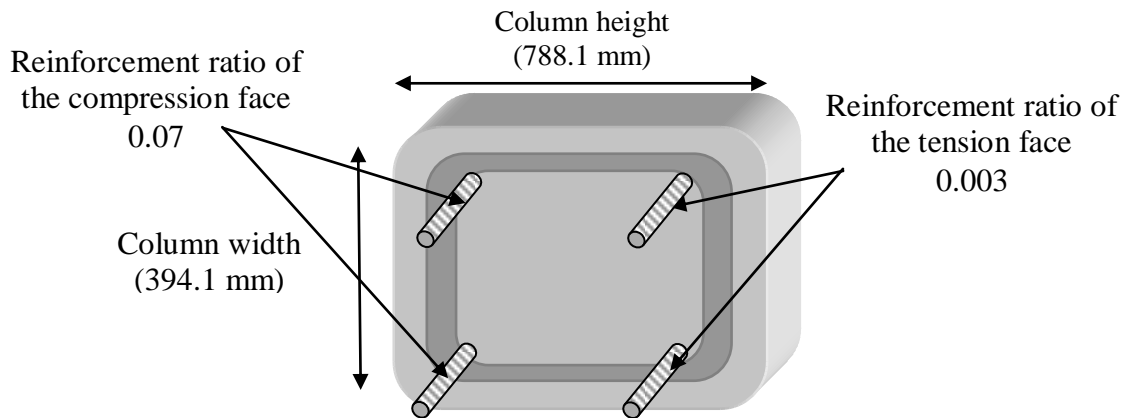

Fig. (6) Optimum design of eccentrically loaded column, *McCormac J. C. 2001*

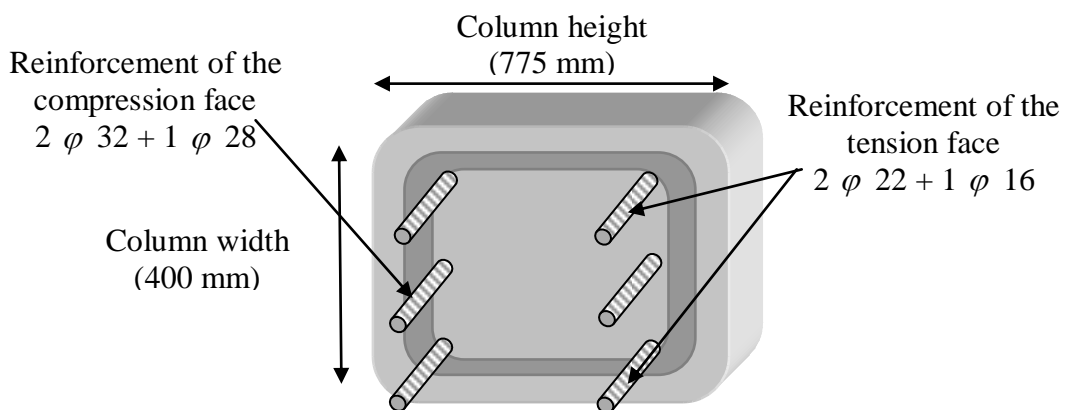

Fig. (7) Optimum design of eccentrically loaded column after rounding the results, *McCormac J. C. 2001*

5.2.2 Uniaxial column example - 2

The second example was solved by *Nawy E. G.* [10]. The column was under load of about $P_n = 2492.3$ kN and $M_n = 284.6$ kN.m, while the material properties were: $f_c = 31$ MPa and $f_y = 414$ MPa. The column section was designed as shown in Fig. (8), with cost of about $0.3386C_c$.

Fig. (9) represents the GAs solution with the optimum section variables, the optimum solution was achieved through 9 iterations with nearly zero constraints violation and a cost of $0.3284C_c$. The suboptimal solution is shown in Fig. (10) after rounding the optimum design variables to get the best practical section near the optimum.

The same example was solved again by using the long column constraint with a cost of $0.3471C_c$, the new optimum section increased as shown in Fig. (11) and (12), obviously to limit the optimum section dimensions within the short column design procedure.

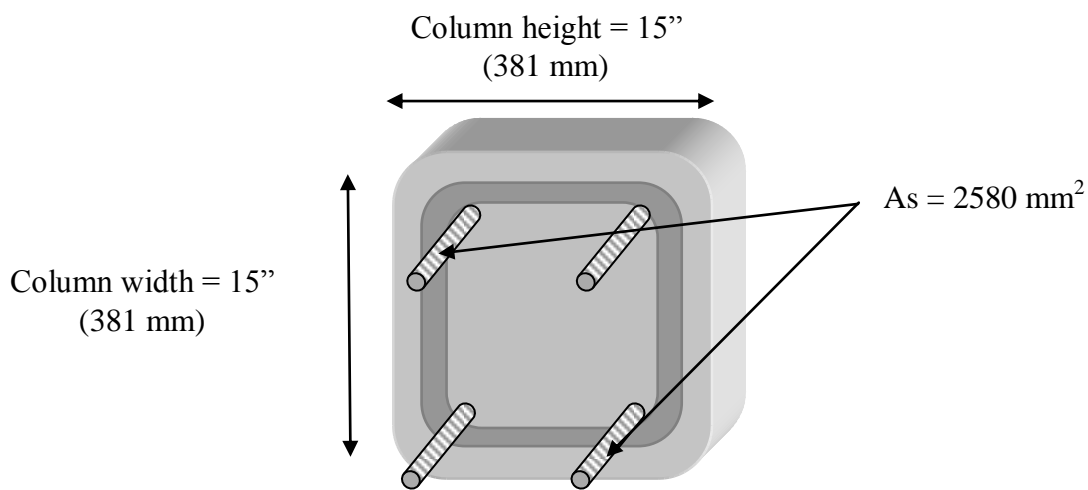

Fig. (8) Design of uniaxially loaded column, *Nawy E. G.* 2003

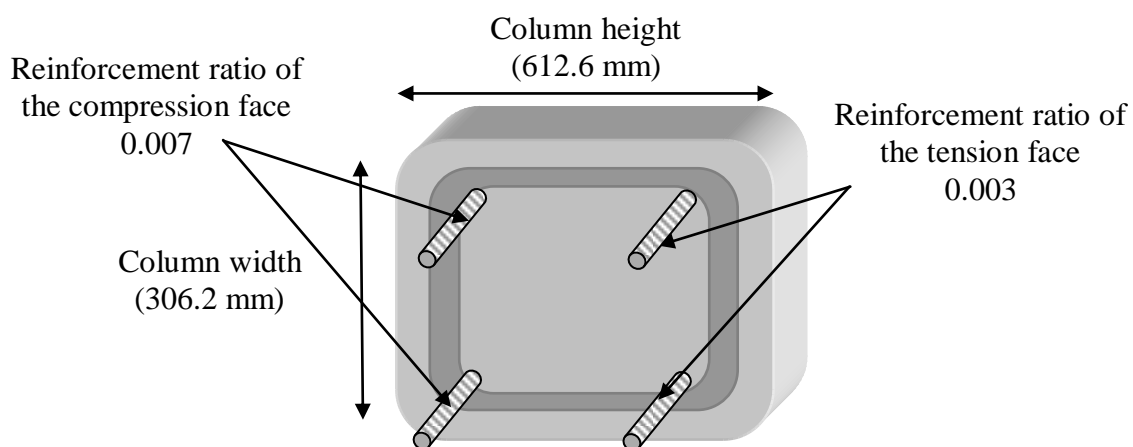

Fig. (9) Optimum design of eccentrically loaded column, *Nawy E. G.* 2003

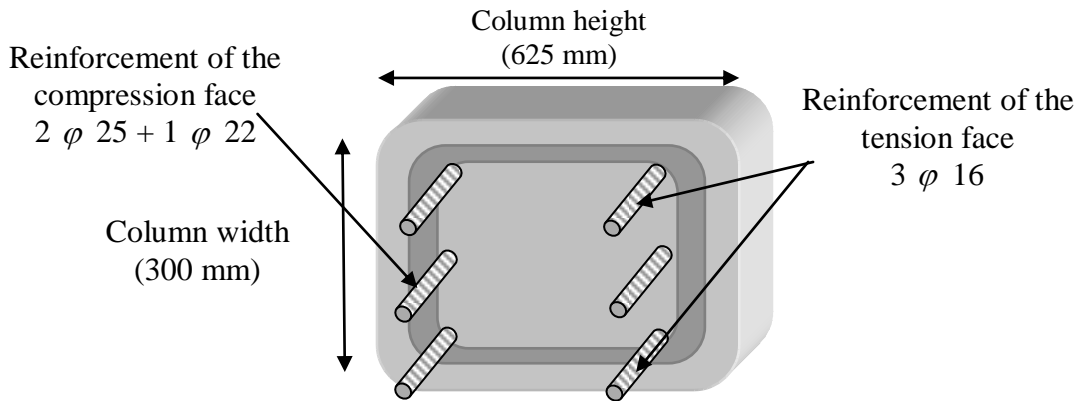

Fig. (10) Optimum design of eccentrically loaded column after rounding the results, Nawy E. G. 2003

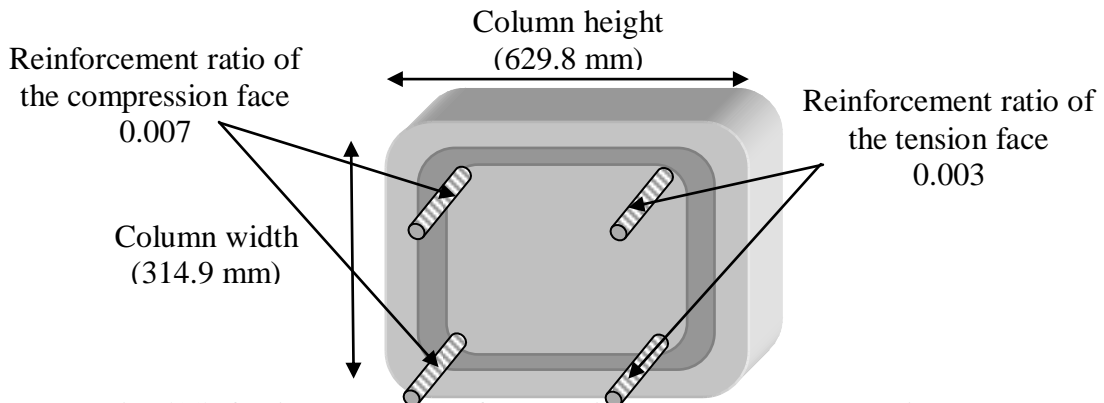

Fig. (11) Optimum design of eccentrically loaded column with long column constraint, Nawy E. G. 2003

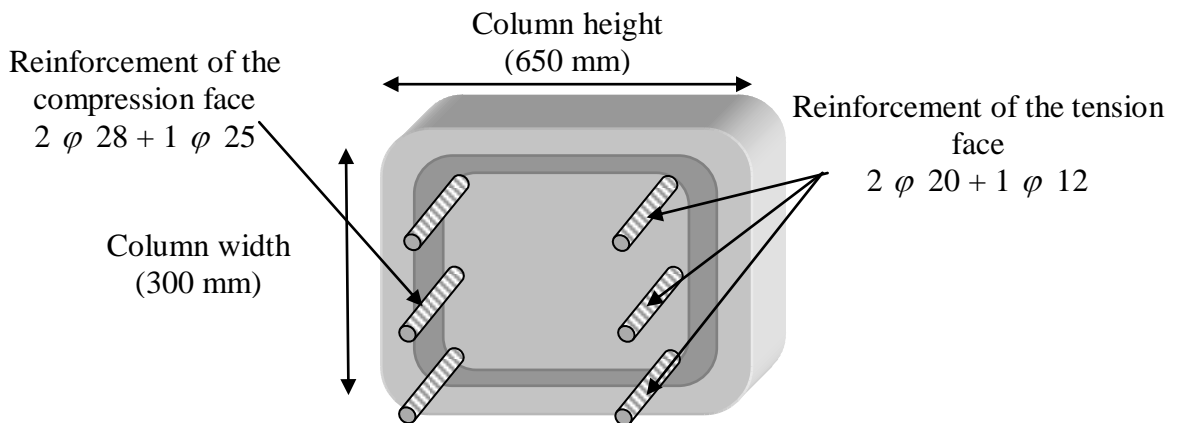

Fig. (12) Optimum design of eccentrically loaded column with long column constraint after rounding the results, Nawy E. G. 2003

5.3 Biaxially Loaded Column Design

Another examples for biaxially loaded column were designed by *Nawy E. G.* [10] and *McCormac J. C.* [12], those examples were designed optimally using the GAs, using the design constraints explained in the previous chapter.

No long column constraint was used here for comparison. As for the interaction between the bars of each side of the section at the corners, it was decided to choose the maximum bar size of the two interacted bars at each corner for practical representation.

5.3.1 Biaxially loaded column example - 1

The first designed column has the details shown in Table (2) with materials property and the applied loads and moments, this column was designed by *McCormac* [12], β factor used in this examples from Fig. (2) was 0.65. The cost values according to the GAs solution had witness a reduction percent of about 26.83 %.

The final designed sections by the author are shown in Figs. (13). While Fig. (14) represents the cost values history of this optimum design showing that the optimum solution was achieved through seven iterations only, also Fig. (15) shows that the this example had achieved a zero violation for constraints after the 7th iteration.

Table (2) Optimum and suboptimum results using GAs , *McCormac J. C. 2001*

Example details	Variables	Author solution	GAs optimum	GAs suboptimum
<i>McCormac</i> $f_c = 27.6$ MPa $f_y = 414$ MPa $P_n = 2402$ kN $M_{nx} = 366$ kN.m $M_{ny} = 306$ kN.m $= 0.65 \beta$	width	558.8	480.5	475
	height	558.8	536	525
	ten. reinf. (y)	8 ϕ 25	0.0042 – ratio	1848 mm ² (3 ϕ 28)
	com. reinf. (y)		0.0012 - ratio	515 mm ² (2 ϕ 16 + 1 ϕ 12)
	ten. reinf. (x)		0.0036 – ratio	1702 mm ² (2 ϕ 22 + 3 ϕ 20)
	com. reinf. (x)		0.0009 - ratio	452 mm ² (4 ϕ 12)
	cost value	0.6161C _c	0.4508C _c	

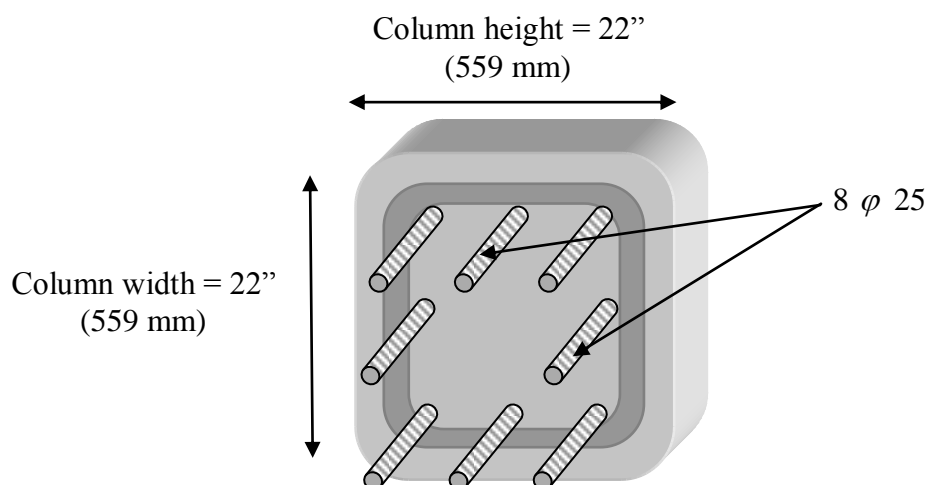

Fig. (13) Design of biaxially loaded column, *McCormac J. C. 2001*

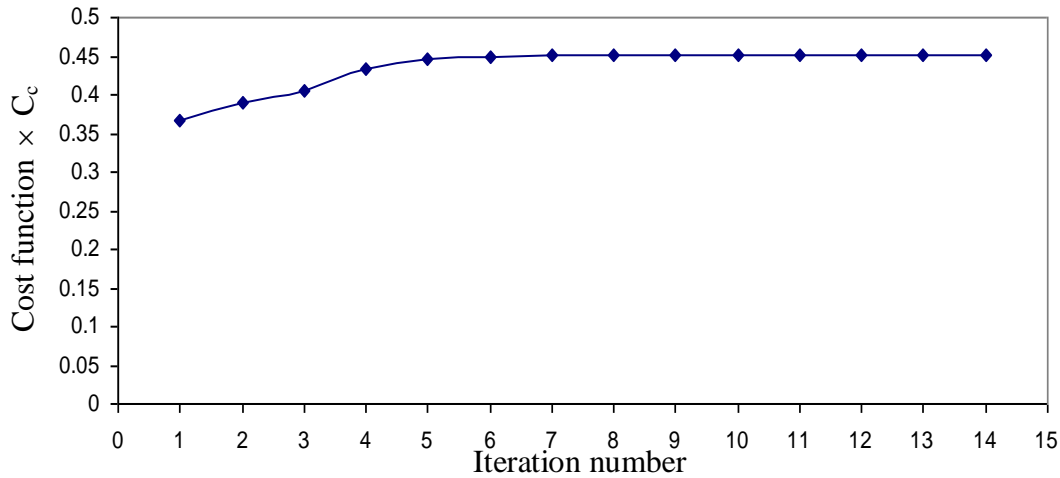

Fig. (14) Cost function scaling through iterations for biaxially loaded column, *McCormac J. C. 2001*

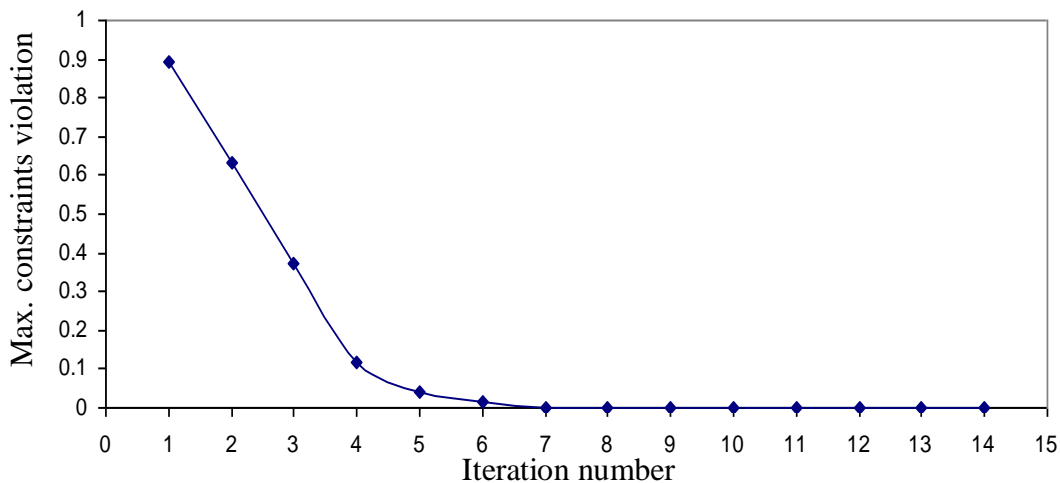

Fig. (15) Maximum constraints violation through iterations for biaxially loaded column, *McCormac J. C. 2001*

5.3.2 Biaxially loaded column example - 2

The second example was designed by *Nawy* [10], the details shown in Table (3) with materials property and the applied loads and moments, β factor used in this examples from Fig. (2) was 0.63, the same value was adopted in solving this example for comparison purposes. The cost difference between the author design and the GAs design is about 26.5 %. Fig. (16) shows the final designed sections by the author, the optimum solution was achieved through 6 iterations with zero constraints violations.

Table (3) Optimum and suboptimum results using GAs, Nawy E. G. 2003

Example details	Variables	Author solution	GAs optimum	GAs suboptimum
<i>Nawi</i> $f_c = 27.6$ MPa $f_y = 414$ MPa $P_n = 1350$ kN $M_{nx} = 271$ kN.m $M_{ny} = 158$ kN.m $\beta = 0.63$	width	305	372.5	375
	height	508	517.3	500
	ten. reinf. (y)	8 ϕ 25	0.0065 – ratio	1848 mm ² (3 ϕ 28)
	com. reinf. (y)		0.0 - ratio	226 mm ² (2 ϕ 12)
	ten. reinf. (x)		0.0035 – ratio	1344 mm ² (3 ϕ 20 + 2 ϕ 16)
	com. reinf. (x)		0.0 - ratio	226 mm ² (2 ϕ 12)
	cost value	0.45881C _c	0.3372C _c	

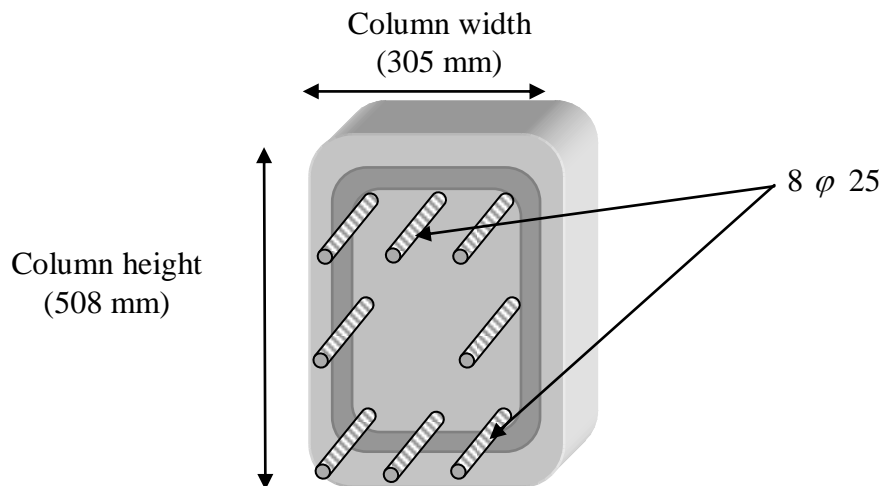
**Fig. (16) Design of biaxially loaded column, Nawy E. G. 2003**

6. Conclusions

Overall, the methodology of the solution with the GAs provides a robust optimum design approach for the challenging problems especially with large constraints requirements, and achieving the design requirements with minimum time and effort. It seems that the cost values according to the GAs solution for biaxially loaded columns, had witness a reduction percent of about 26.83 % in the first example and about 26.5 % in the second one, as compared to the traditional design method by using the same materials price for the two designed solutions. While a reduction in the cost values of about 1 – 3 % for the uniaxially loaded columns was gained using the GAs optimum design method. Also, the cost savings in the axially loaded columns was about 50%. which make this method on the top of the available choices for any engineer seeking the optimum design.

Conducting the completely new optimization problem for the long columns, with all of its designing constraints, and not only the special case for the buckling factor, which was used in this study. And for a better way optimizing the type of the used columns for the structure whether it was short or a long one, instead of using only one design direction, such as the short column which was enforced in this study.

7. References

- 1 - Hultman M., 2010, "Weight Optimization of Steel Trusses by a Genetic Algorithm - Size, Shape And Topology Optimization According to Eurocode", Report TVBK-5176, ISSN 0349-4969, M. Sc. Thesis,
- 2 - Coley D. A., 1999, "An Introduction to Genetic Algorithms For Scientists And Engineers", World Scientific Publishing. Department of Structural Engineering, Lund Institute of Technology, Lund University, Sweden.
- 3 - Mitchell M., 1998, "An Introduction to Genetic Algorithms", The MIT Press, Cambridge, Massachusetts, London, England.
- 4 - Fadaee M. J. and Grierson D. E., 1996, " Design Optimization of 3D Reinforced Concrete Structures", Structural Optimization, Vol. 12, No. 2-3, pp. 127 – 134.
- 5 - Camp C. V., Pezeshk S. and Hansson H., 2003, " Flexural Design of Reinforced Concrete Frames Using a Genetic Algorithm", Journal of Structural Engineering, Vol. 129, No. 1, pp. 105 - 115.
- 6 - Kwak H. G. and Kim J., 2008, " Optimum Design of Reinforced Concrete Plane Frames Based on Predetermined Section Database", Computer Aided Design, No. 40, pp. 396 – 408.
- 7 - Aschheim M., Hernandez-Montes E. and Gil-Martin L. M., 2008, " Design of Optimally Reinforced RC Beam, Column, And Wall Sections", Journal of structural Engineering ASCE, Vol. 134, No. 2, pp. 231 – 239.
- 8 - Sahab M. G., 2008, " Sensitivity of The Optimum Design of Reinforced Concrete Flat Slab Buildings to The Unit Cost Components And Characteristic Material Strengths", Asian Journal of Civil Engineering (Building and Housing), Vol. 9, No. 5, pp. 487 – 503.
- 9 - Building Code Requirements For Structural Concrete (ACI 318 M-08), Reported by ACI Committee 318.
- 10 - Nawy E. G., 2003, " Reinforced Concrete – a Fundamental Approach", Fifth Edition, Pearson Education Inc.
- 11 - Sinha N. C. and Roy S. K., 2011, "Fundamentals of Reinforced Concrete", S. Chand & Company Ltd.
- 12 - McCormac J. C., 2001, " Design of Reinforced Concrete", Fifth Edition, John Wiley & Sons. Inc.

The work was carried out at the college of Engineering. University of Mosul